

## **№2261369**

FIELD: oil producing industry.

SUBSTANCE: invention relates to oil recovery machinery, namely, to submersible centrifugal pumps designed for operation in wells with sand troubles. Proposed oil-well centrifugal pump has motor connected with lower pumping unit by of suction member in form of housing with shaft and supply holes. Suction member is furnished with foam metal filter placed between housing and shaft to form ring spaces in between. Supply holes are arranged in housing within the limits of filter mounting. Areas of cross section of inner ring spaces and supply holes are made commensurable.

EFFECT: prevention of penetration of mechanical impurities into pumping units, reduced abrasive wear of working members of pump, improved operation reliability.

2 dwg

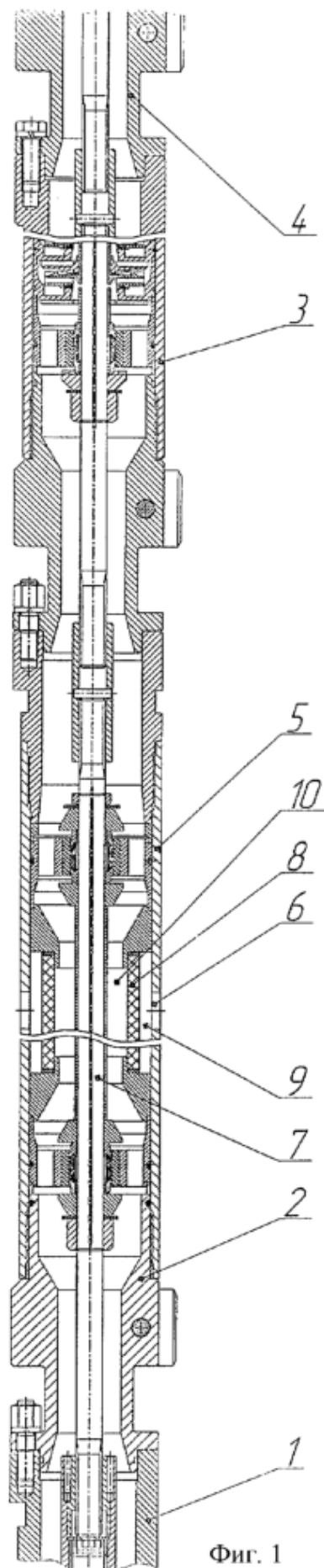

Фиг. 1