

№2304729. Abstract

(54) STAGE OF CENTRIFUGAL TURBINE MACHINE

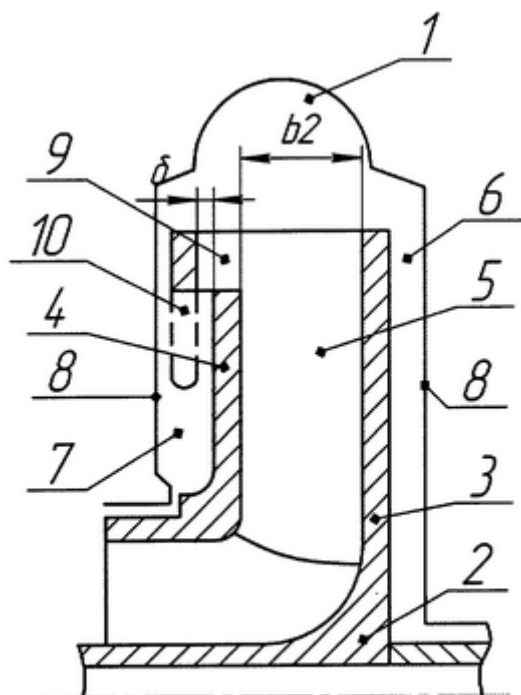

Фиг. 1

FIELD: mechanical engineering.

SUBSTANCE: stage of centrifugal turbine machine comprises outlet branch pipe, wheel provided with driven and driving disks, and blades interposed between the disks. The peripheral section of the wheel has an abrupt thickening in the meridional section. The inner side of the disk downstream of the thickening is mounted with a spaced relation to the face of the disk upstream of the thickening. The value of the face space does not exceed 0.2-0.3 of the width of the wheel at the outlet.

EFFECT: enhanced efficiency.

1 cl, 4 dwg